

e@vidya

INFORMATION & COMMUNICATIONS TECHNOLOGY

Standard VI



Government of Kerala
Department of Education

State Council of Educational Research and Training (SCERT), KERALA
2017

THE NATIONAL ANTHEM

Jana-gana-mana adhinayaka jaya he
Bharatha-bhagya-vidhata,
Punjab-Sindh-Gujarat-Maratha
Dravida-Utkala-Banga
Vindhya-Himachala-Yamuna-Ganga
Uchchala-Jaladhi-taranga
Tava subha name jage,
Tava subha asisa mage,
Gahe tava jaya gatha.
Jana-gana-mangala-dayaka jaya he
Bharatha-bhagya-vidhata,
Jaya he, jaya he, jaya he,
Jaya jaya jaya jaya he!

PLEDGE

India is my country. All Indians are my brothers and sisters.

I love my country, and I am proud of its rich and varied heritage. I shall always strive to be worthy of it.

I shall give my parents, teachers and all elders respect, and treat everyone with courtesy.

To my country and my people, I pledge my devotion. In their well-being and prosperity alone lies my happiness.

Information & Communications Technology-VI

Prepared by :

State Council of Educational Research and Training (SCERT)

Poojappura, Thiruvananthapuram - 12, Kerala

Website : www.scertkerala.gov.in, e-mail : scertkerala@gmail.com

Phone : 0471 - 2341883, Fax : 0471 - 2341869

Typesetting and Layout : SCERT

Printed at : KBPS, Kakkannad, Kochi - 30

© Department of Education, Government of Kerala

Foreword

Dear children,

We are living in a world where we use, refine and transfer information from many sources in many ways. Computers are the foundation for this information transfer. It is because of this that at least basic knowledge of computers is essential for leading a life realising the direction and momentum of the new world.

This book for class VI is prepared in the light of these requirements. We also learn how to use ICT in all subjects in addition to familiarising the basic principles of ICT. I wish this book helps you in learning all other subjects as well.

With best wishes,

Director
SCERT

ACTIVITY BOOK DEVELOPMENT TEAM

Chairman

K Anvar Sadath
Executive Director, IT @ School Project

Members

Girish Mohan P.K.,
Master Trainer, IT@School Project,
Kannur

Saju S.S.,
Master Trainer, IT@School Project,
Thiruvananthapuram

Sajimon P.N.,
Master Trainer, IT@School Project,
Ernakulam

Mahesan K.G.,
Master Trainer, IT@School Project,
Kozhikkode

Sabarish K.,
Master Trainer, IT@School Project,
Malappuram

Muhammed Abdul Nasar K.,
Master Trainer, IT@School Project,
Kozhikkode

Abdul Hakkim CP
Master Trainer, IT@School Project,
Malappuram

Muhammed Aslam A.R
A.E.O. Mankombu

Pradeep Kumar Mattara
Master Trainer, IT@School Project,
Malappuram

Rajesh S. Vallikkode
B.P.O., B.R.C Pathanamthitta

P Yahiya
G.G.M.G.H.S.S., Chalappuram

Hassainar Mankada
Master Trainer, IT@School Project,
Malappuram

English Translation

Biju Donald
HSST, St Joseph's HSS , Thiruvananthapuram

Rathi S Nair
HSST, GHSS, Bigbazar
Palakkad

Soniya S Ravi
HSA, Concordia Lutheran HSS
Peroorkada, Thiruvananthapuram

Language Experts

S Bindhu
Associate Professor (Retd),
University College, Thiruvananthapuram

Dr. Lalitha M
Librarian (Retd), SCERT, Kerala

Dr. K Reghunadhan Pillai
Principal UIT, Sasthamcotta,
Kollam

Dr.Thomas Kuruvila
Additional Director of Collegiate
Education (Retd), TVM

Artist

Suresh E (Cartoonist), Co-ordinator, Animation Programme, IT@ School Project

Academic Co-ordinator

Riyana Ansari, Research Officer, SCERT Kerala

Contents

1. Lovely Letters	07-15
2. Globes and Maps in the Computer	16-24
3. Concepts into Pictures	25-31
4. When Lines Meet.....	32-41
5. To the World of Information	42-49
6. Into the Wonderful World of the Sky	50-55

**Certain icons are used in this
book for convenience**



For further reading



Let's assess



Extended Activities

Chapter 1

Lovely Letters



“Its Meenakshi’s brother’s birthday. I’m also invited”. Aswathy called out holding up the invitation card.

“Wow! Look, how beautiful it is.” All the friends read the card one by one.

“That’s right...! It’s very beautiful”, agreed everyone.

“I should also make a card like this for my birthday.” said Aswathy.

“Shall we make one now”? Aami was excited and seemed to be in a hurry.

They started to make an invitation card. What would they have written? What picture would they insert ? Shall we make such a card?

At the outset, we should discuss and decide the sentences we need. Aswathy’s invitation card is in English, right? Let ours too be in English.



BIRTHDAY CELEBRATION

.....Invite on

12.08.2017

.....

.....

.....

.....

.....

Activity 1.1

Let's Type an Invitation Card

In the earlier classes, we learnt the uses of the software (Word Processor) which helps us to enter text and make the font attractive. We can use the same for making the invitation card.

Open Word Processor Software and start entering the text.

Place your fingers on the exact keys

On which letters of the keyboard do we have to place our fingers when we type? Observe the picture...

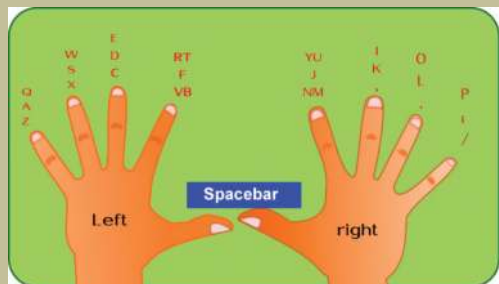

Don't we need to save the file after typing?

For that, save the card to your folder giving it the file name 'invitation'.

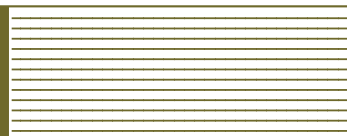

Activity 1.2

Let's make our invitation card attractive.

Hope you have made your card.

How can we make it attractive?

Write down your suggestions.

You can save the file by clicking here.



Remember to save whenever you make changes to the file.



- ◆ We need beautiful letters.
- ◆
- ◆
- ◆

How can we change the font?

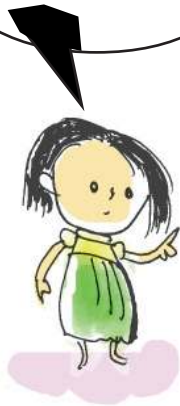

Let's Change the Font

How can we make the letters even more beautiful?

First select the sentence that is to be changed.

Observe the **Font Box** (Figure 1.1) in the formatting tool bar. Click on the arrow mark to its right side and choose the most suitable font.

Try changing the **Font** .

Look at the text 'Birthday Celebration' in different fonts (Figure.1.2).

Among these, which one did you find the most attractive title?

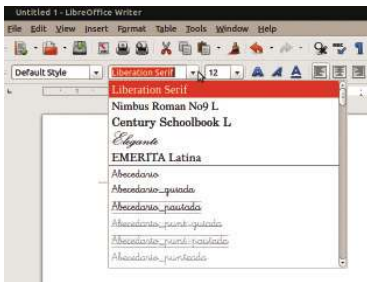

Figure 1.1 Different Fonts

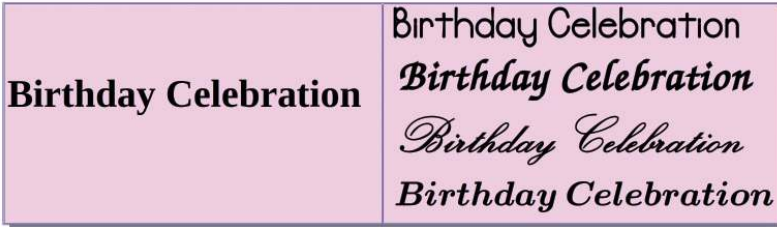

Figure 1.2 Different fonts for the title

Let's give colour to the fonts

We can make the **Font** more attractive by adding colour to it. We can add colours to the fonts in as mentioned below.

- ◆ Select the sentence to be coloured.
- ◆ Click on the arrow mark to the right of the **Colour** tool in the tool bar.(Figure 1.3)
- ◆ Click on the suitable **Font Colour**.

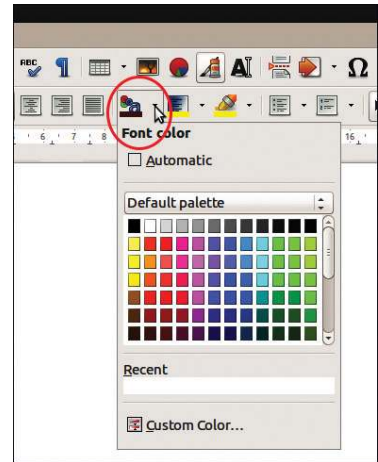

Figure 1.1 Colour window

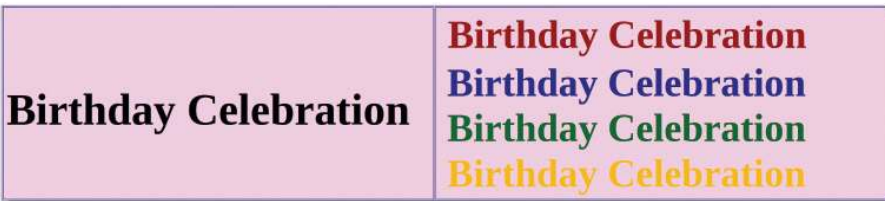
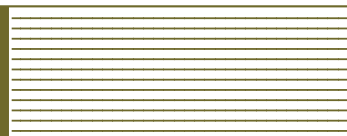

Figure 1.4 Title in various colours.

We have learnt to change the size and thickness of fonts in previous classes. Let's use those tools here. Complete the table given below.

Font Name	<input type="text" value="Liberation Serif"/>	Change the font of the letters
Font Size	<input type="text" value="12"/>
Bold	
Italics		Create slanting letters



Underline		Underline the letters
Align Left	
Center	
Align Right	
Font Color	

Table 1.1 Formatting Tools

Activity 1.3

Let's Add Pictures

There are many pictures in your computer. You can insert any of these in your invitation card. How can we do this?

- ◆ Bring the cursor to the spot where you wish to insert the picture. Then click on the Image button. (see Figure.1.5)
- ◆ Select the picture you would like to insert in your invitation card from the window that opens up. Now click on the **Open** button. Hasn't the picture been inserted into the invitation card?



Figure1.5 Tool to insert the picture

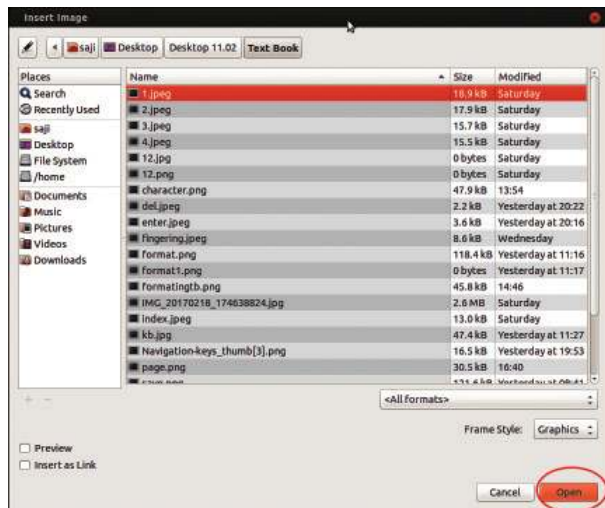

Figure 1.6 Window from which picture can be selected.

How can we adjust the size of the picture?

- ◆ Can't you see small green coloured squares around the image? Click on it and try to move the mouse (see Figure 1.7). Do you see the size change?
- ◆ Now we can click on the image and place it in the most suitable places.



Figure 1.7 Nodes used to change the size of the image.

The invitation card is now ready (Figure 1.8).



Figure 1.8 Invitation card

When the size of the picture is changed...

When you click and drag the mouse on the tiny squares that appear around the image, is it the breadth or the length that changes, or both?

What happens when you press the **Shift** key in the keyboard while you drag?

Activity 1.4

An Invitation Card in Malayalam

Write the names of your classmates who plan to celebrate their birthdays in the days to come

.....

.....

.....

Don't we need to change the keyboard layout to Malayalam for typing Malayalam letters?



Let's prepare an invitation card in Malayalam for them.

Write down the sentences that are to be typed in the invitation card.

പ്രിയപ്പെട്ട

.....

.....

ജന്മദിനാശംസകൾ

സ്നേഹപൂർവ്വം

.....

(തയാറാക്കിയവരുടെ പേരുകൾ)



Figure 1.9 Tool to change the keyboard layout

In the previous classes we had learnt how to change the keyboard layout to Malayalam by clicking on the keyboard indicator on the top **Panel** of the computer Desktop. Don't you remember that?

Now start typing the birthday wishes that you have composed. For that, you can select any of the **Fonts** like Rachana, Keraleeyam or Chilanka in the *Word Processor*. Now start typing using the Malayalam keyboard.



Figure 1.10 Keyboard layout in Malayalam

I am the friend of compound letters





After typing the letters, let's make the invitation card more attractive by adding colour and pictures.

◆ Press and hold the Shift key to write the letters on the upper levels of the keys.

◆ If we add  (ഓ) mark between two letters we get a compound letter.

ക+ഓ+ക=കക്ക ക+ഓ+ത=കത ക+ഓ+യ=ക്യ

◆ If we want to get a 'Chillaksharam' we need to press  and  along with its consonant

ന+ഓ+ = ന്ന ര+ഓ+ = ര്ന ഉ+ഓ+ = ഉ്ന

◆ If we add "ര" to any letter, we get

ക+ഓ+ര=ക്ര ച+ഓ+ര=ച്ര ശ+ഓ+ര=ശ്ര



Let's assess

- ◆ We celebrate Father's Day on the third Saturday of June. Prepare a greeting card to wish your father on this day using *Word Processor*.
- ◆ Prepare an invitation card in *Word Processor* to invite parents for the PTA meeting in your school.

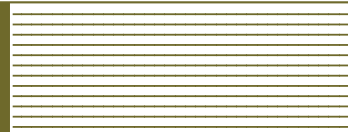

- ◆ Prepare a Poster with suitable pictures for the awareness campaign on the importance of conservation of water using *Word Processor*.
- ◆ An article with photos and the report of the agricultural activities conducted in your school is to be displayed on the school notice board. Prepare the article using *Word Processor*.



Extended Activities

- ◆ Every year the Moon Day is celebrated to commemorate man's landing on moon. There are pictures of the moon and informations relating to moon in your computer. Prepare a poster using all these details.
- ◆ Every year we celebrate June 26 as 'International Day Against Drug Abuse and Illicit Trafficking.' Prepare a notice showing the importance of this day, using the computer.



Chapter 2

Globes and Maps in the Computer



This year’s study tour is to Delhi. The teacher has given the list of the places that the team intends to visit.

Neethu and friends were trying to locate on a globe the places given in the list. But they couldn’t find some of the places on their small globe. Neethu remembered then what her Social Science teacher had said about various digital globes and maps like *Marble* and *Google Earth* in the computer the size of which could adjust to our requirements. They decided to search for these places in *Marble Globe*.

How can we open *Marble* globe and locate the places of our choice?

Activity 1.1

Finding places using Marble software

Open *Marble* software in the order give below:

Applications → *Education* → *Marble*.

Using the mouse adjust the globe to view Asian Mainland on the monitor. Zoom in to view the landmass containing India, using the scroll wheel of the mouse.

Delhi Tour - First Day
Noida - Breakfast
Okhla Bird Sanctuary
Delhi - Juma Masjid
Red Fort
Lunch
.....
.....
.....

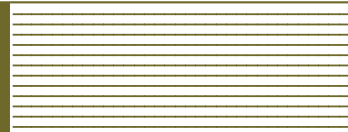

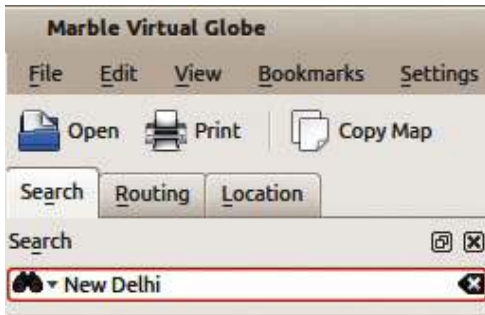

Figure 2.1 Search box in the Marble window

Find New Delhi on the globe. If necessary the **Search** box can be used to help locate places. (Figure 2.1)

Now locate and write down the important places near New Delhi in this way.

◆ Agra

◆

Activity 1.2

Finding aerial distances using Marble

We can find out the aerial distance between two places using *Marble* software. Let's see how we can measure the distance between New Delhi and Agra.





Digital Maps and Globes

Various Globes and Maps to help in geographical studies are available on the internet. *OpenStreetMap*, *Wikimapia*, *Google Maps*, *Google Earth* etc., are examples. Have you heard of Bhuvan? It is an initiative of the Indian Space Research Organisation (ISRO)?

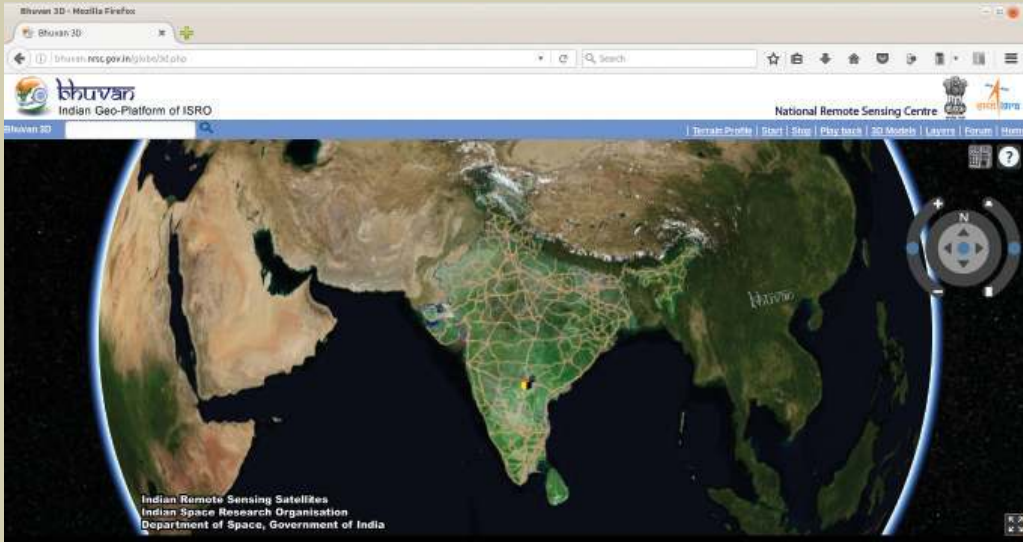

Find New Delhi in Marble Globe and click the right button of the mouse over it and select **Add Measure Point** from the menu that appears.

Then find Agra and repeat the process as before.

Don't you see a line appearing to connect both places? The aerial distance between these places is shown here.

In the same way find the distance between your district headquarters and New Delhi using *Marble* globe and write it down.

.....

What is the distance between your district headquarters and the State capital?

.....

Would you like to have these maps stored in your computer for further use? How would you save them to your computer?

Activity 1.3

Creating and saving maps

The process of creating and saving maps with the help of *Marble* is detailed below.

- ◆ Enlarge and adjust the areas which you want in *Marble* globe.
- ◆ Using **Flat View** technique, create a map of the chosen area (Figure 2.2).

A globe can be made into a map

If we want the map view rather than the view of the place on the globe, what shall we do? Select **Mercator View** or **Flat View** from the **Map View** given on the left side of the window. You will be able to see the map of the place.

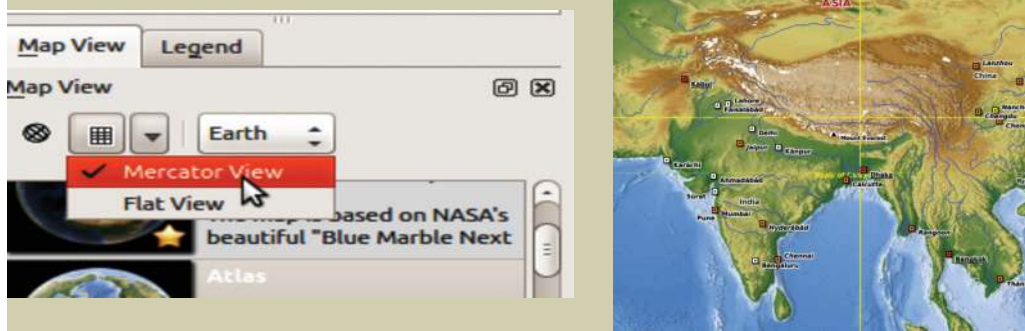

Figure 2.2 Visualising maps using Marble software.

- ◆ Click on **Export Map** of the **File** menu
- ◆ Give a suitable name to the map in the Window that opens and save it in your folder.

You have learnt about various rulers of medieval India and their empires, haven't you? Try to locate their kingdoms using *Marble* globe.

Don't forget to save the information to your computer.

An address for every place

After locating the places they plan to visit, Neethu had a doubt. How can one find the way to all those places? Teacher said it would be easy to find places using a mobile phone with GPS facility.

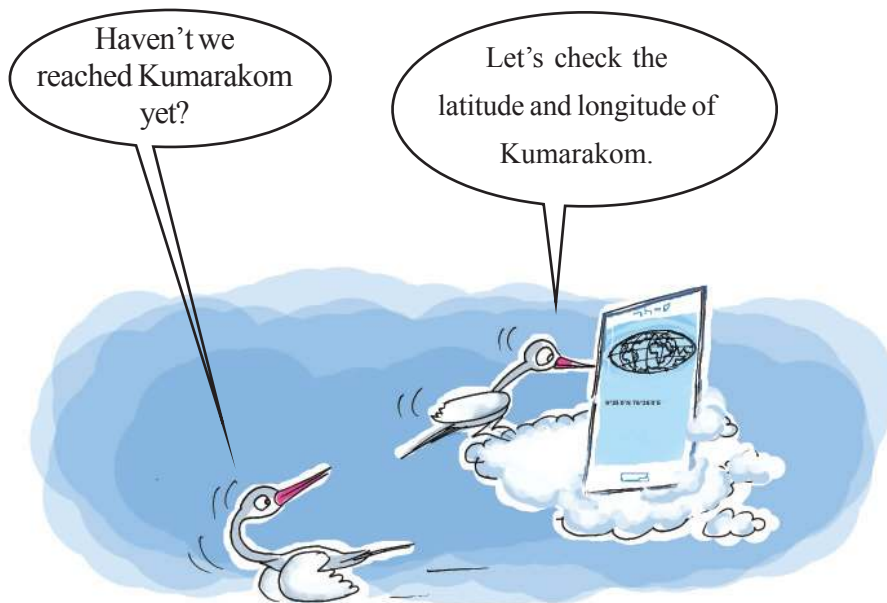

GPS (Global Positioning System)

You know that the imaginary lines drawn vertically and horizontally across the globe are the longitudes and latitudes, don't you? A place on the earth can be located on the basis of its longitude and latitude. You have also learnt that these lines are drawn on the basis of precise angular measurement. By the signals received from the artificial satellites in space, we can determine the latitude, longitude and height of a place using the GPS facility. Today GPS is widely used in mobile phones, vehicles and many other devices.

Haven't you seen the lines marked around the globe in *Marble* software (Figure 2.3)? They are classified as latitudes and longitudes. These imaginary lines are the basis for deciding the exact location of a place on the earth.

Find the latitude which divides the globe into northern and southern hemispheres using *Marble*.

Also find the prime meridian that divides the globe into the eastern and western hemispheres.

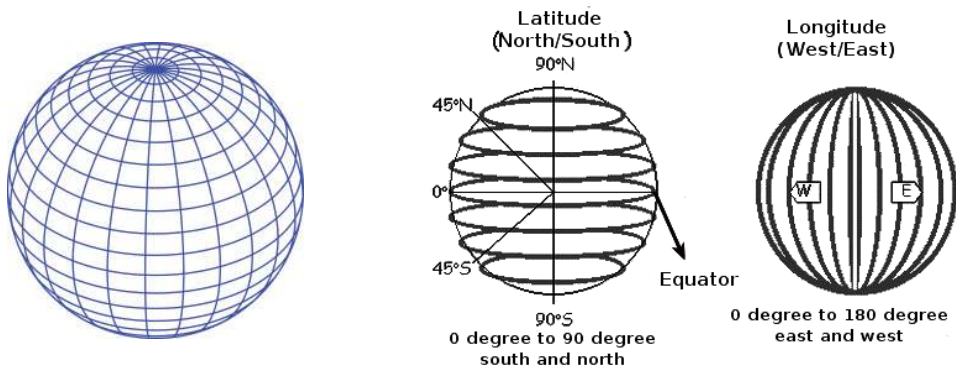

Figure 2.3 Latitudes and Longitudes

If you zoom in further you will be able to see more latitudes and longitudes



Activity 1.4

Finding major latitudes and longitudes

Open *Marble* software and find all the major latitudes and longitudes and observe their characteristics. Complete the Table 2.1.

Peculiarities	Latitude/Longitude
Major latitude passing through India
North Pole° north
South Pole°
The longitude opposite to 0° Standard Meridian

Table 2.1 Major longitudes and latitudes.

We have seen that every area on the earth has specific latitudes and longitudes. How can we find the latitudes and longitudes of our surrounding areas using *Marble*?

Activity 1.5

Find the latitude and longitude of an area

Let’s learn how to find the latitude and longitude of your district headquarters.

- ◆ Open *Marble* software, locate your district headquarters and zoom in on it.
- ◆ Click on the sign given along with the name of the place. In the window which opens you will be able to see its latitude and longitude. Select the necessary details from it and write them below.

Place

Latitude

Longitude



Eclipses in Marble

Other than general maps there are historical maps as well as those that can tell us the average rain fall and temperature of any region in *Marble*. Apart from this we can also see areas where Solar eclipses and Lunar eclipses occur at various times.

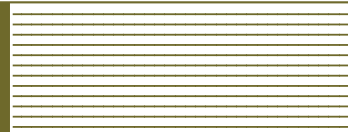

Latitudes and Longitudes of my locality

Not all places are recorded in the Marble. How can we find out the latitude and longitude of unnamed places in Marble software?

Move your mouse through different regions of Marble. Don't the latitudes and the longitudes of those areas appear against 'Position' as seen on the status bar?

Could you identify the latitude and longitude of your place? Try to do it.

Position: 75° 36' 37.5"E, 12° 03' 02.3"N

Every angular distances in degree is divided into 60 equal minutes. Each minute is divided into 60 seconds.



Let's assess

- ◆ Find out the aerial distance of various district headquarters to Thiruvananthapuram using Marble and prepare a table of your findings.
- ◆ Observe the continents through which the Equator passes using Marble. Export the map which includes that and save it to a folder
- ◆ With the help of Marble software complete the table given below:

Place	Latitude	Longitude
New Delhi		
Thiruvananthapuram		
Mumbai		
Srinagar		



Extended Activities

- ◆ Find out the latitudes and longitudes of your neighbouring districts in *Marble* software and create a table.

- ◆ Find out the areas which were under Iltumish, a ruler of medieval India in *Marble*. Export the maps of such areas and save them in your computer.
- ◆ Using *Marble* Software find out the latitude and longitude of important places in different climatic zones (you must have learnt in Social Science) and create a table.

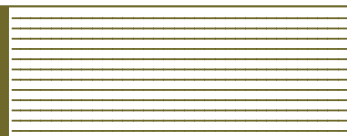

Chapter 3 Concepts into Pictures

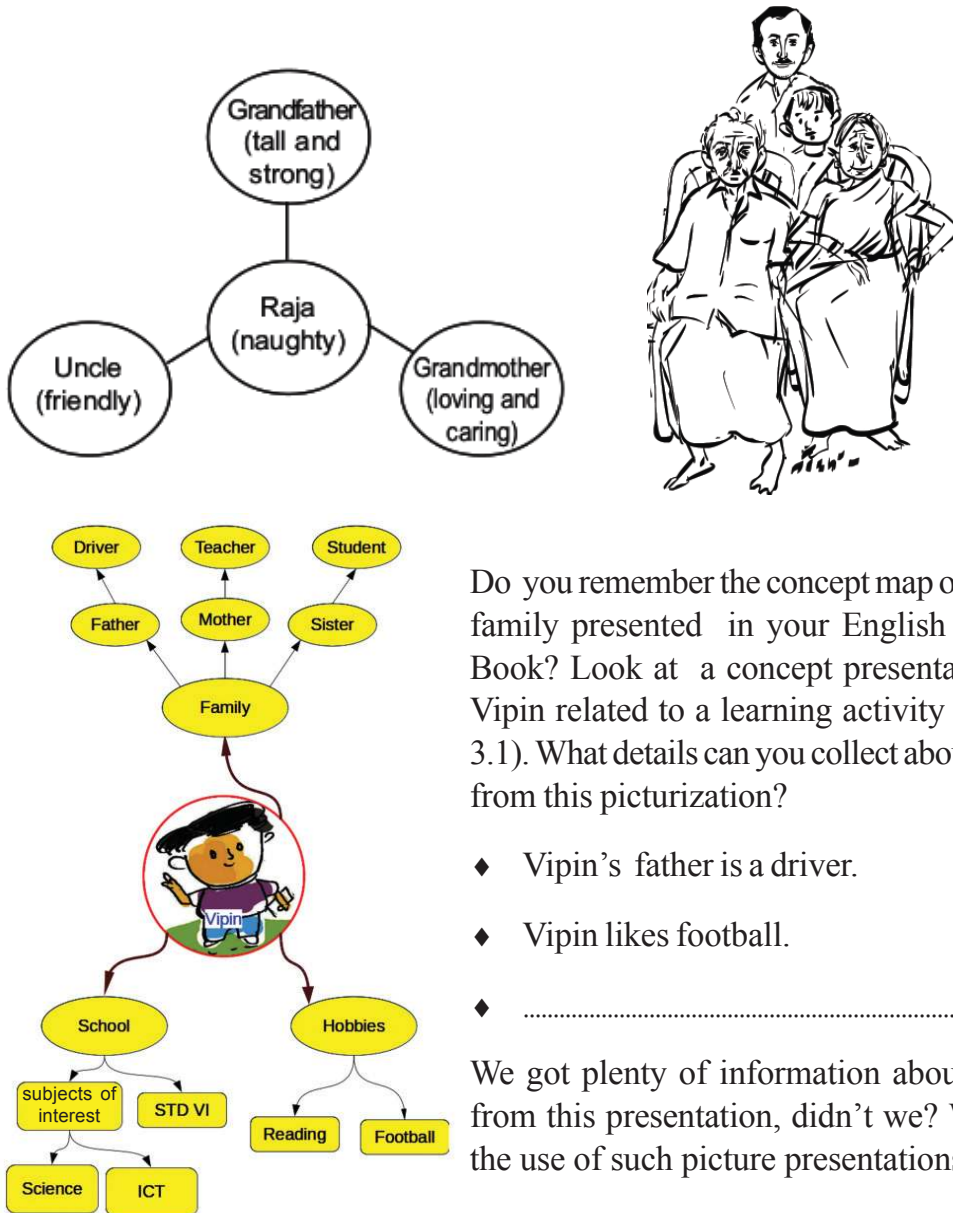

Figure 3.1 Concept map on Vipin

Do you remember the concept map of Raja’s family presented in your English Course Book? Look at a concept presentation by Vipin related to a learning activity (Figure 3.1). What details can you collect about Vipin from this picturization?

- ◆ Vipin’s father is a driver.
- ◆ Vipin likes football.
- ◆

We got plenty of information about Vipin from this presentation, didn’t we? What is the use of such picture presentations?

- ◆ Help to understand details easily.
- ◆

Activity 3.1

My Family

Observe the picture (Figure 3.2) that will help you to draw a family tree. Note the names of your family members in it and complete the family tree. You can also make necessary modifications to the picture, if needed.

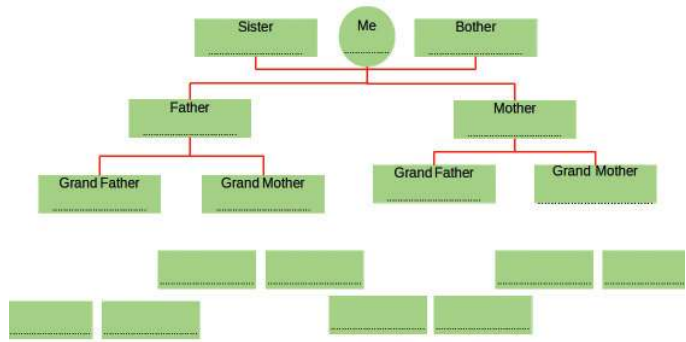

Figure 3.2 Family Tree

Activity 3.2

Different kinds of Picturisations

Our course books use a lot of pictures to illustrate ideas.

Try to find out more picturisations and complete the table given below:

Picturisation	Description
	<p>Ice is the solid form of water. When it is heated it becomes water. When boiled the liquid form of water changes into its gaseous form or water vapour. When water vapour cools it becomes water again. And when water is cooled it turns into ice.</p>

Table 3.1 Picturisations and explanations

Let's create these pictures using the computer



Activity 3.3 Computer Picturisation

Look at the picture given in the Basic Science textbook. (Figure 3.3) Here you can see the various ways in which different ingredients can be separated from various mixtures. The *LibreOffice Draw* software in our computer helps us to draw such pictures.

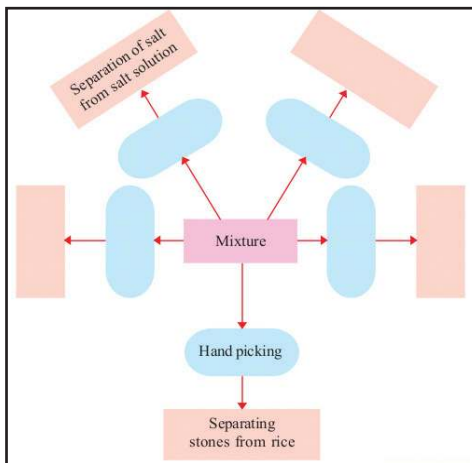

Figure 3.3

Separating mixtures - Picturisation

Open *LibreOffice Draw* software in the **Office** menu and get familiar with the window. (Figure 3.4) Let's examine how we can create the illustration given in Figure 3.3 in our computer.

- ◆ Draw rectangles and a circles.

Using **Rectangle** and **Ellipse** tools given in the tool bar on the left in the *LibreOffice Draw* window, draw as many rectangles and circles as needed.(Figure.3.5)

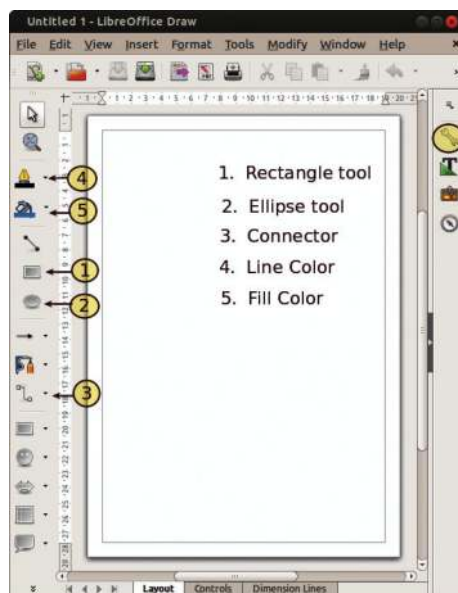

Figure3.4 LibreOffice Draw Window

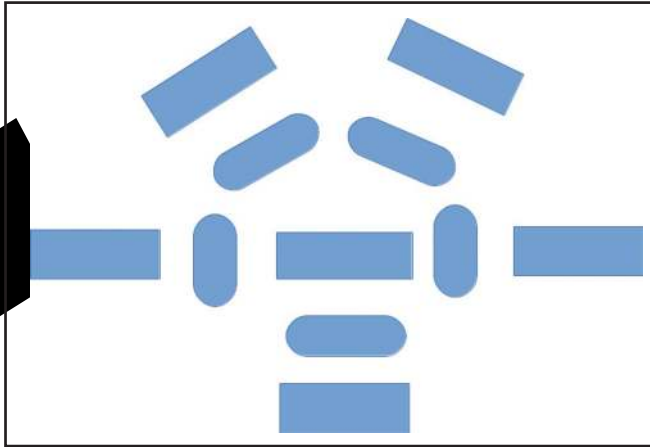

Figure.3.5 Shapes given in the Draw Canvas.

◆ **Include words**

When you double click on the rectangles and circles, a cursor will appear to type words on it. Here you can add words by typing. You can also add Malayalam words by making changes to the keyboard settings.

◆ **Draw Connectors**

Select **Connector** from the tool bar on the left side of the Draw Window(Figure 3.6). When the mouse reaches the circle or rectangle we have drawn, we can see the connecting points (glue points) on the sides .

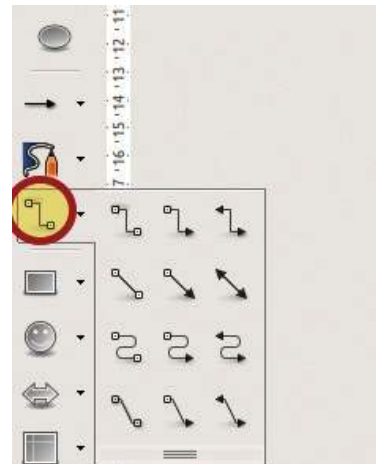

Figure 3.6 Connectors

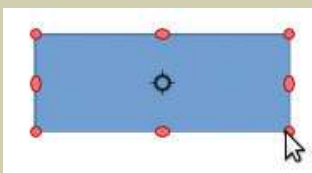

Figure 3.7 To rotate the shapes

Rotate the rectangle

When you click again on the selected rectangle you will see red marks (Figure 3.7). You can click on the marks in the corner and rotate the shape as required.

Don't forget to save what you have done after completing the activity.

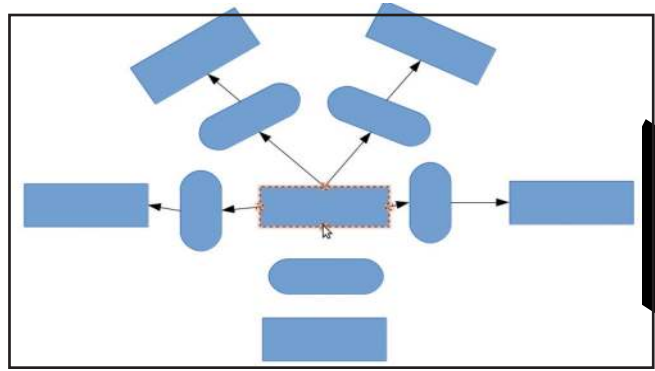



Figure 3.8 Illustration of the use of connectors

We can connect shapes by clicking and dragging the glue points of rectangles or circles to the glue points of the images to be connected (Figure 3.8). After connecting two images, notice how the connected lines get adjusted when the position of the connected images are changed.

Activity 3.4

Let's make the picture attractive

- ◆ Let's make the rectangles attractive.

To add colour to the shapes and make them attractive, select them and use the **Fill Colour** Tool  from the toolbar on the left. The border colour of the rectangle can be changed using the **Line Colour** Tool .

This facility can also be used to make the connector lines attractive.

Another way of doing this is by using the **Properties** window on the right side of the Side Bar . (Figure. 3.9)

In this manner, make the picture attractive and then save it.

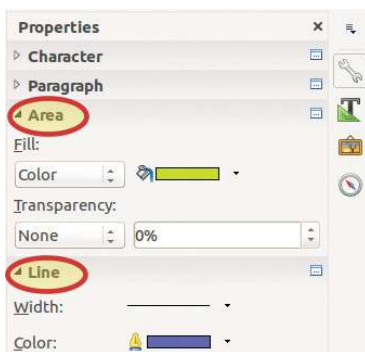
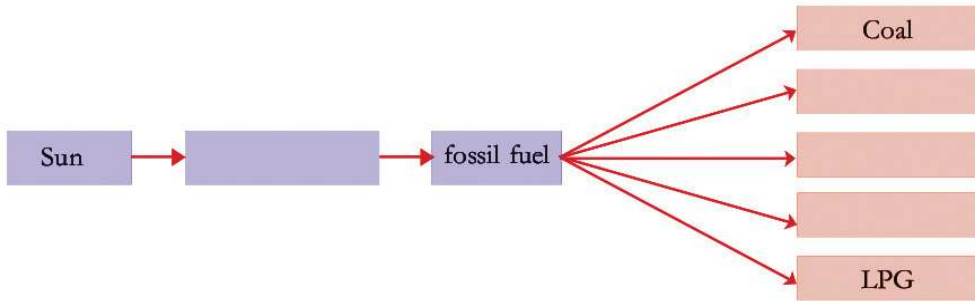

Figure 3.9 Properties



Let's assess

How do petrol and diesel vehicles depend on the sun for energy? Prepare a flow chart on fossil fuels using your computer, as in the model.



- ◆ Given below is the picture drawn by Rinu on her computer about the classes in her school. Prepare a similar picture about your school using *LibreOffice Draw*. Improve the picture, including a few more details.

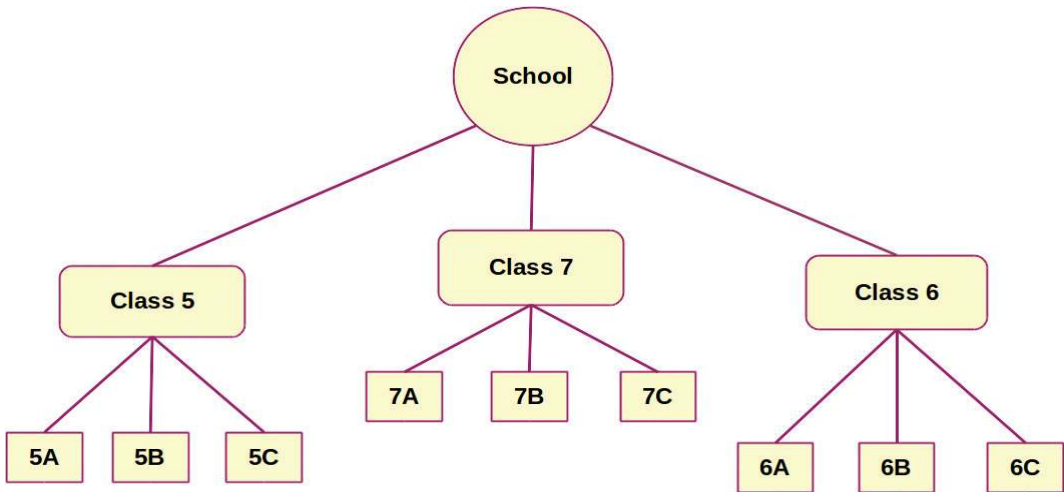

Extended Activities

- ◆ What do you know about water? Collect as much information as possible about water and create a concept map using *LibreOffice Draw*.

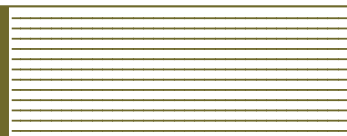

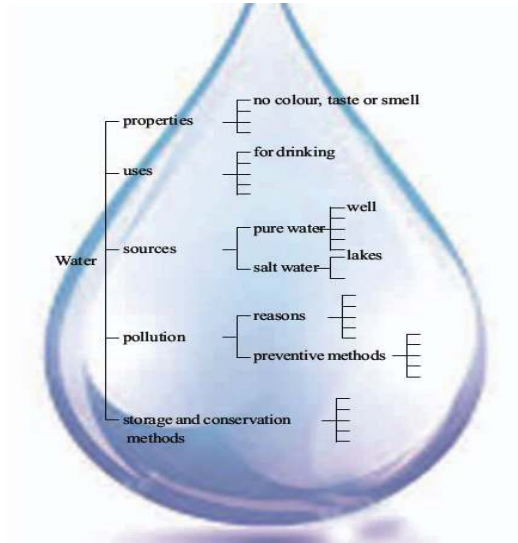

Chapter 4

When lines meet...

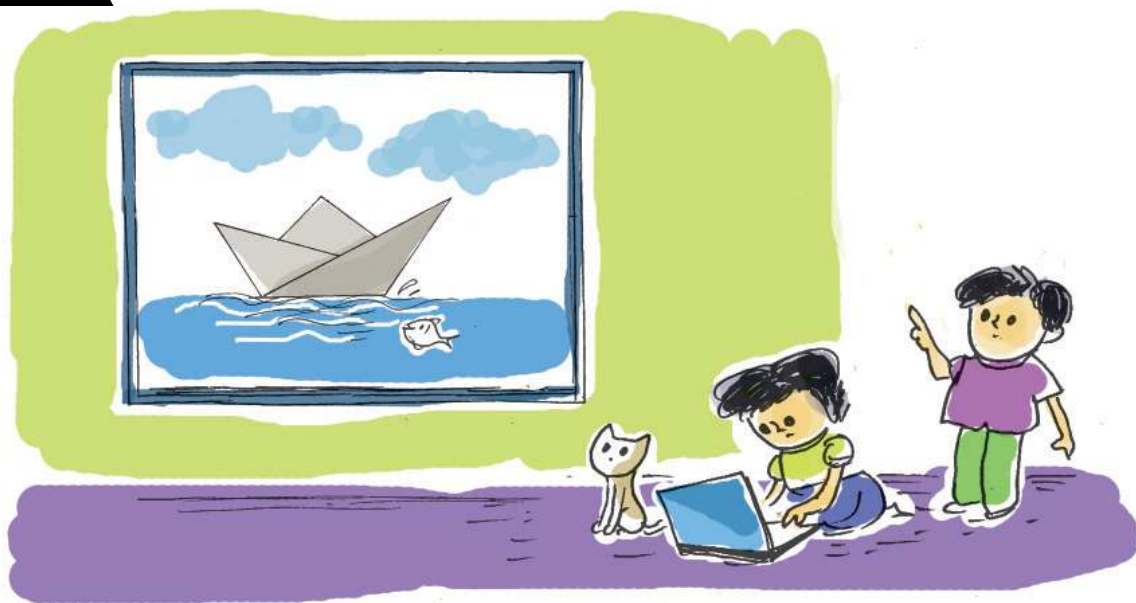

Naina is busy with a mathematics project. The topic of the project is ‘the relation between two adjacent angles when two lines intersect’.

She drew several pairs of lines, measured the angles and prepared a list.

Jaffer who had been observing all this, asked her ‘Can’t this be found using *GeoGebra* Software.’

Naina wanted to know how *GeoGebra* could be used to find the relation between angles.

We have already learned how we can make mathematical figures using *GeoGebra*. Now let us help Naina to complete her project using this software.



GeoGebra

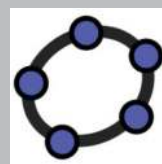

GeoGebra is a free interactive software used to draw and observe the properties of geometrical shapes.

The number of angles

The number of angles obtained is determined by the way in which the lines intersect.

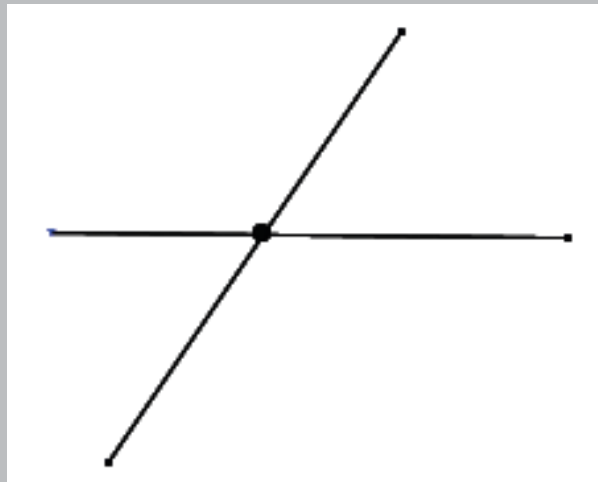
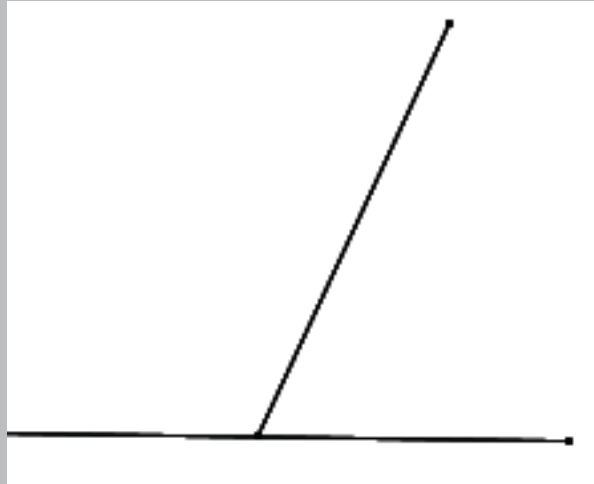

Activity 4.1

The Properties of adjacent angles, when two straight lines intersect.

When two straight lines intersect, angles are formed. Let's examine the properties of these angles using *GeoGebra* Software.

- ◆ Open *GeoGebra* in the following order.

- ◆ Select **Line Tool**  from tool box and draw a line in the open window.

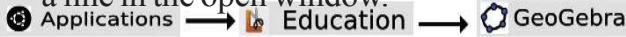



Figure 4.1 To open GeoGebra

- ◆ Mark two points through which the line passes by clicking the mouse (figure 4.2)
- ◆ Select **Segment Tool**  from the tool box.

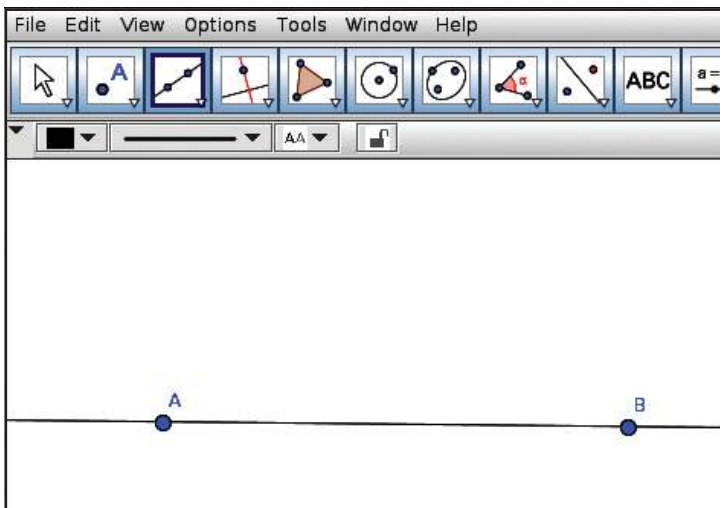



Figure 4.2 Straight line passing through two points.

- ◆ Draw another line that intersects the first line between the two points marked earlier (figure 4.3).



To draw a line of a specific length

Use the tool **Segment with**

Given Length  from the toolbox to draw a line with a specific length.

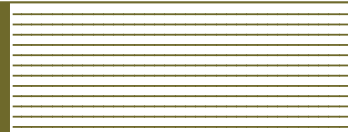

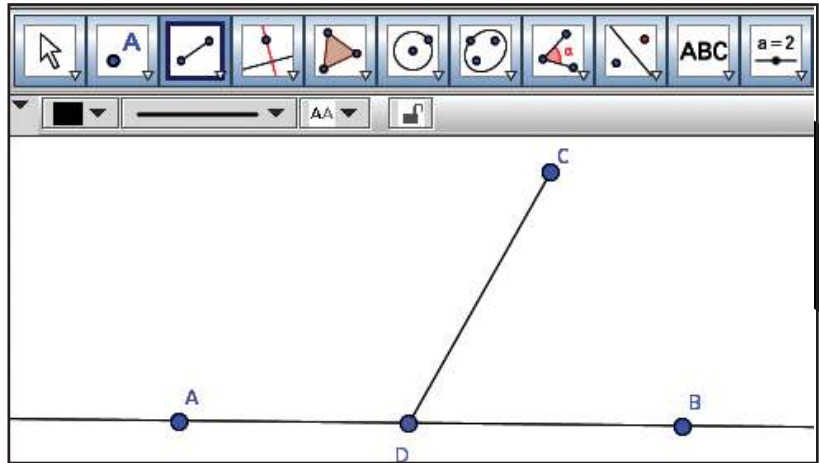

Figure 4.3 Two lines that intersect.

How many angles are formed when the line CD intersects the line AB in the figure? (Figure 4.3)

.....

Which are they?

$\angle BDC$,

How can we measure these angles?

- ◆ Take **Angle Tool** from the tool box .
- ◆ Click on the points in the order B, D, C which decide the angles.
- ◆ You will be able to see the measurement of angles (Figure 4.4).
- ◆ In the same way measure the other angles too.

If the labels of points are not visible

If the labels of points are not visible, right click on the point. Mark **Show Label** in the window that appears.

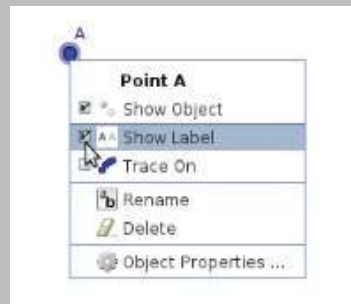



To draw an angle to a given measurement

You can make use of the tool **Angle with Given Size**  for making angles of specific measurement in *GeoGebra*

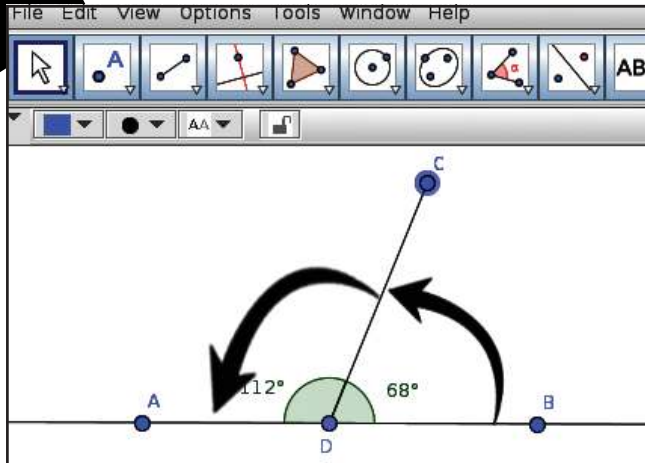

Figure 4.4 Measuring the angles

Remember to measure the angles in the order B, D, C. Find out what happens if you measure in the order C, D, B?



Find the sum of the two angles.

To convert the measurement of the angle to a whole number

We may get the measurement of angles in the form of decimals. To convert them into whole numbers, click on the icon **Options** in the menubar and click on the **0 Decimal places** in 'Rounding'.

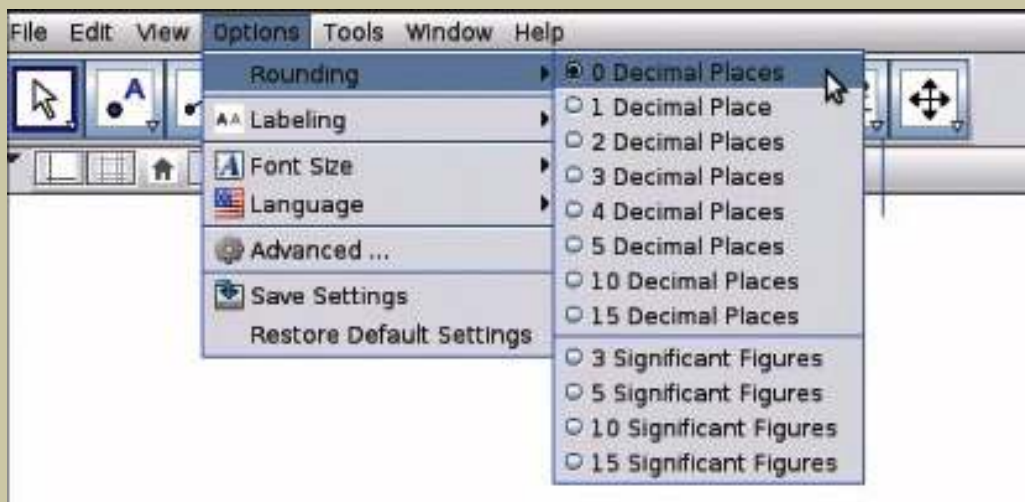

Think about the sum of the angles formed when a line intersects another line. Will it be the same in all cases?

Don't we need to draw many pictures to find it?

What if we do it in *GeoGebra*?

- ◆ Move point C using **Move Tool**  in the tool box.
- ◆ Write the changes in the measurement of angles in the table below and find the sum (Table 4.1).

Try moving the other points. Does the measurement of the angle change?



No.	Angle BDC	Angle CDA	Sum
1	68°	112°	
2			
3			
4			
5			
6			
7			

Table 4.1 Sum of angles

Write from the findings

.....

.....

.....

Now, save the file for future use.

Activity 4.2

When lines intersect

Draw two lines that intersect as shown in the picture. (Figure 4.5)

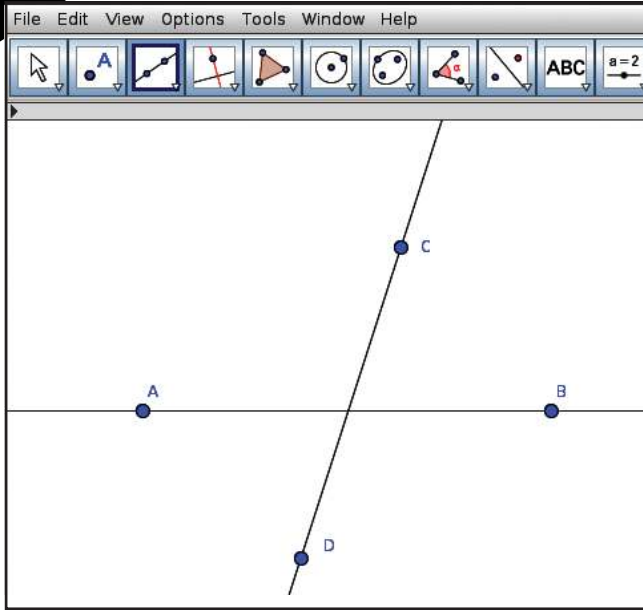
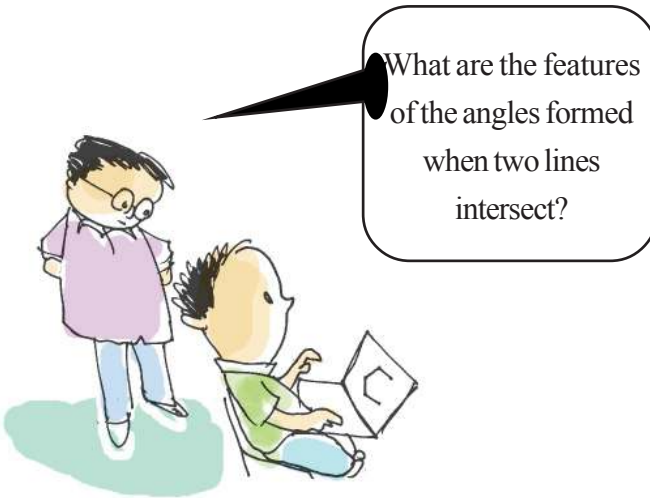

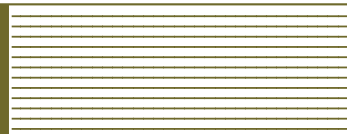

Figure 4.5 Two intersecting lines.



- ◆ To find the point of intersection of two lines, choose **Intersect Tool**  from tool box and click on each line. You will be able to see the point of intersection.



Measure the four angles formed at the meeting point

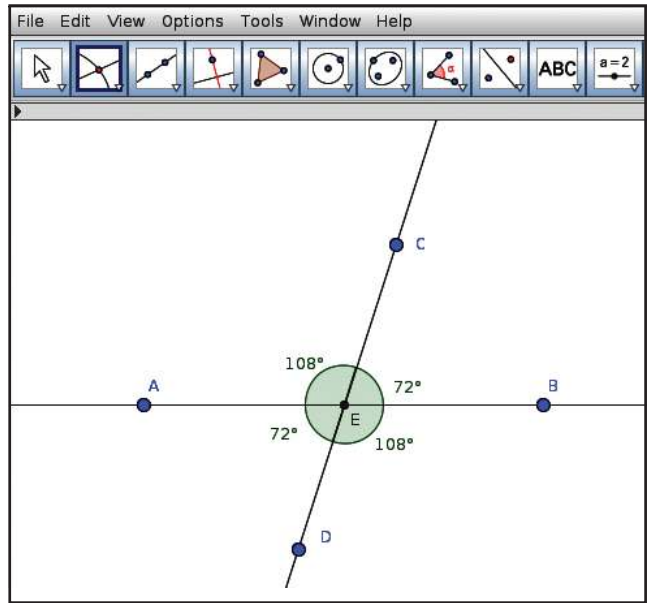

Figure 4.6 Meeting point

- ◆ Verify the measurement of opposite angles.
- ◆ Move the points using the **Move Tool**.
- ◆ Record the changes in each angle in Table 4.2 and find their characteristics.

No	Angle BEC	Angle AED	Angle CEA	Angle DEB
1	72°	72°	108°	108°
2				
3				
4				
5				
6				

Table 4.2 Features of angles.



Let's assess

- ◆ Construct a triangle using the **Polygon tool** and save it. Measure all its three of its angles.
- ◆ Construct a triangle. Using **Move Tool** try to move the sides and record the measurement of angles in a table. Find its sum and write your inferences in your note book.



Extended Activities

- ◆ Construct a polygon. Using **Move Tool**, move its sides and enter the measurement of the angles in a table. Find the sum of the angles and record your inferences in your note book.
- ◆ Draw the diagrams given below using **Polygon Tool**.

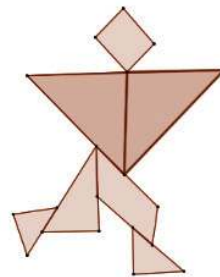
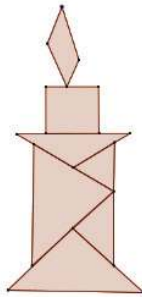
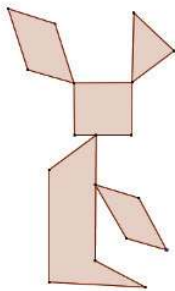

Chapter 5

To the World of Information



How diverse is our world! Different climatic zones and the unique flora and fauna found in them provide amazing experiences. This diversity is what makes the earth so beautiful and rich. Here we see a digital album prepared by Mini on this diverse world and its creatures.



Desert

Its very hot here. At times it is very cool at night. Water is very scarce. Plants and trees are very few in number.

Camel

It can live without water for many days
It can live in extreme heat
It is known as the ship of the desert



From where did Mini get all these pictures and the information?

Viju is quite amazed to learn that she got all the pictures off the Internet.

This increased his doubts.

- ◆ Can we get all the pictures we need from the Internet?
- ◆ How can we search for pictures on the Internet?
- ◆ Can we save them to our personal computer?

There are innumerable items on the Internet in the form of information and pictures. These have been provided by people across the world for various purposes.

Now let's see what are the prerequisites for collecting data from the internet.

- ◆ Internet facility should be available on our computer.
- ◆ Software for searching for information on the Internet has to be installed in the computer.

We have learned about different climatic zones and the varieties of plants and animals that exist in each area and their characteristics in the lesson 'World of Diversities' in the Social Science Course Book. We too can create a digital album like the one Mini made. What pictures do we need?

WEB BROWSERS

Information is transferred on the internet in page format. These pages are known as Web Pages. Web Pages are displayed on the computer using special Web browsing software. Mozilla Firefox, Chromium, Microsoft Edge, Safari, etc. are examples of web browsers.

- ◆ Pictures that depict the geographical features of different climatic zones.
- ◆ Pictures that depict the characteristics of plants and animals in those regions.
- ◆ Pictures that depict the social life of people in those regions.
- ◆

Shall we collect these from the Internet?

Let's find the way to search for the necessary pictures on the Internet.

Activity 5.1

Prerequisites for collecting pictures from the Internet.

What information do we need from the Internet for the album?

Let's draw a table and list them.

Details of picture	Key words
Images of the Desert, its special features and the living things in it.	<ul style="list-style-type: none"> ◆ date palm ◆ camel ◆ kalahari ◆
The Tundra region and its animal and plant life.	<ul style="list-style-type: none"> ◆ iglu/igloo ◆ inuit ◆
Equatorial zone.	<ul style="list-style-type: none"> ◆ equatorial ◆ semang ◆ rosewood tree ◆

Table 5.1 Key words

KEY WORDS

We can use certain words (related to the information we seek) to reach the page with the information we need from among all the other information available on the internet. Such words are called key words.



Is your table ready?

Imagine you want to collect images of the Tundra region and of the polar bears which live there, using the key words you have prepared.

Let's see how it can be done using the steps given below.

Activity 5.2

Let's collect pictures

First, we have to open a web browser. Aren't you familiar with web browser software? Let's use Mozilla Firefox.

Applications → Internet → Firefox Web Browser
Click your mouse in this order to open the Firefox browser.

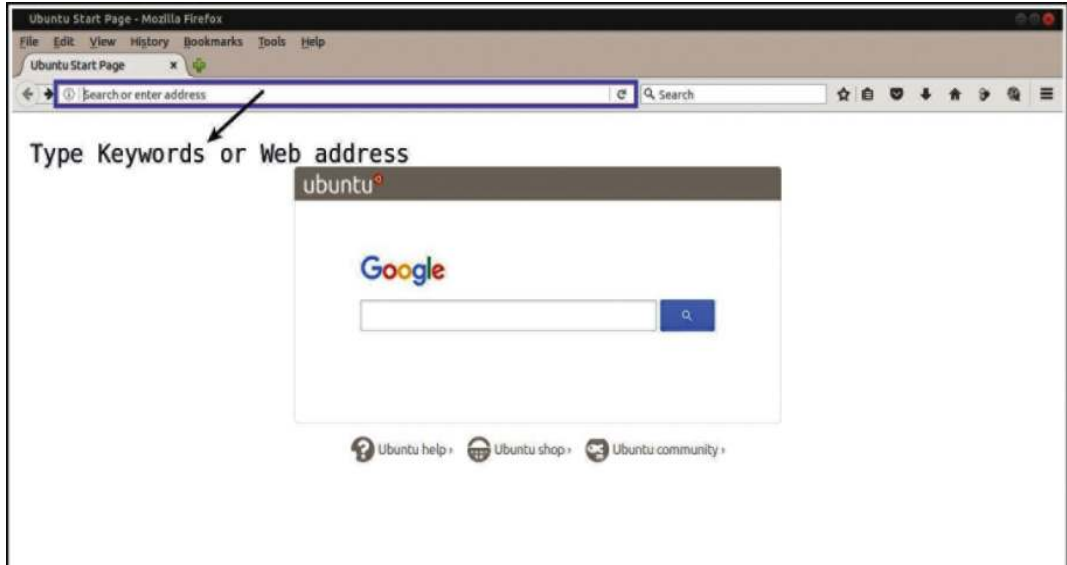

Figure 5.1 Browser window.

- ◆ In the search box given in the browser, type the keyword.(Figure 5.2)
- ◆ Press the **Enter** key on the keyboard.

- ◆ In the window which opens you can see the details of the key word given.

To search for images, click on the Images icon on the top right corner of the window (Figure 5.2).

Search Engines

There are certain systems on the Internet which help us search for pictures and information. They are known as Search Engines.

Google, Duck Duck Go, Yahoo, Bing, etc, are some of the important Search engines.



Attention !!!

Not all information provided on the internet is true.

Although the majority of the information is right, there may be some fake information also.

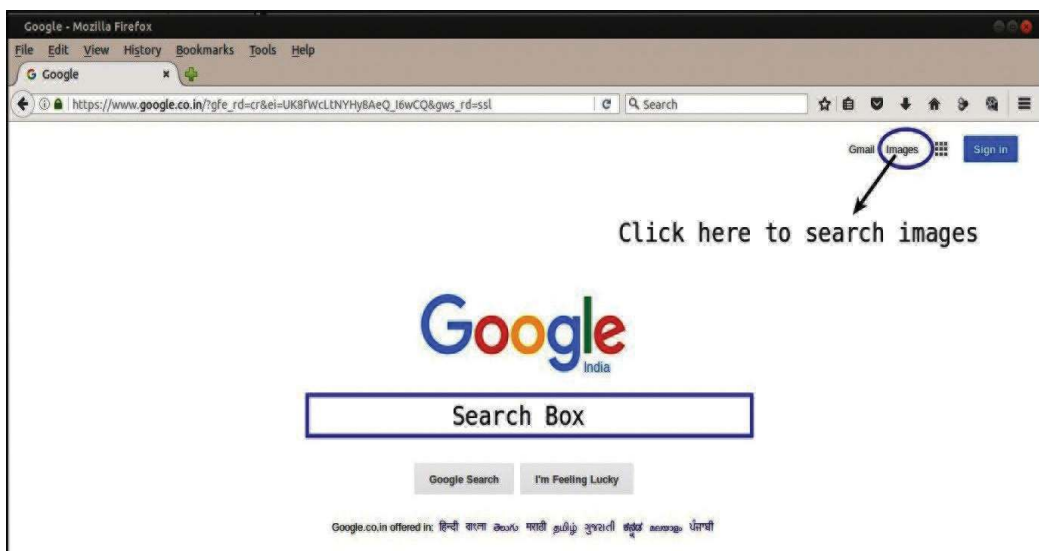

Figure5.2 Search engine window

- ◆ See how many pictures have appeared on screen based on the keywords we have given! Surely many of these pictures will be useful to us.

Vinton G Cerf



He is known as the father of the Internet. He was born in 1943 at New Haven in America.

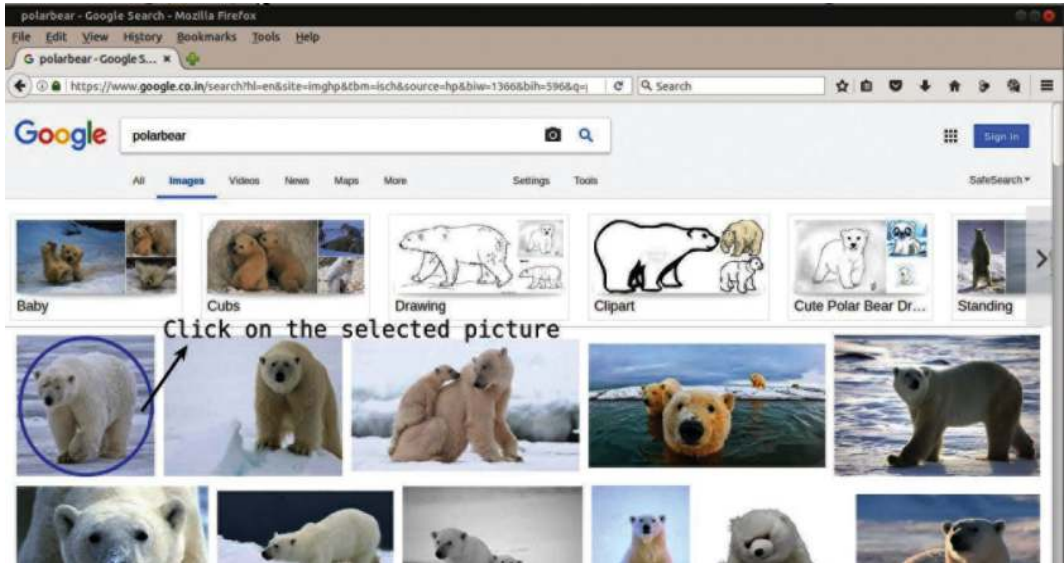

Figure 5.3 Images displayed by search engine.

How can the selected image alone be saved?



Look at the window which displayed the images. (Figure 5.3) You don't need all the images here, do you?

To save the images we need from the above, follow the steps given below:

Activity 5.3

To save the image

- ◆ Click on the image that we need.(Figure 5.3)
- ◆ Then click the right mouse button on the image (Figure 5.4) which now appears in an enlarged form.

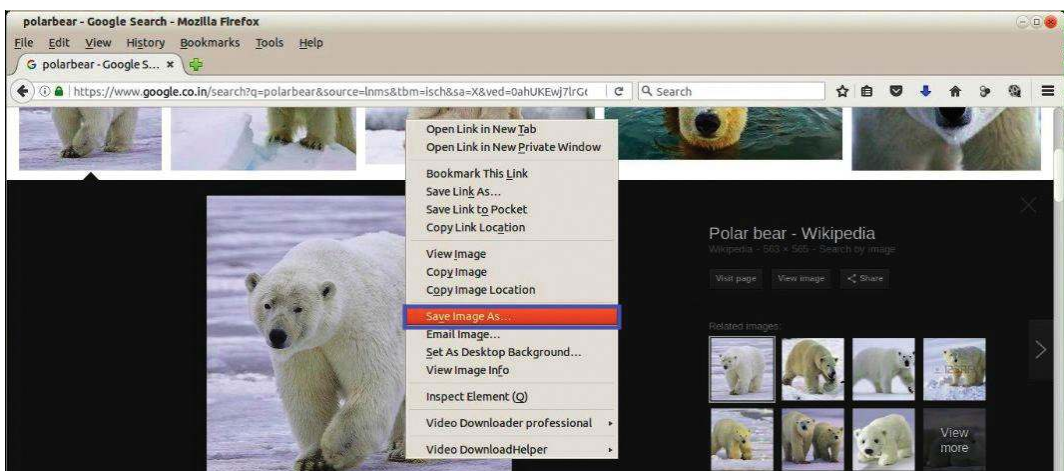

Figure 5.4 Saving the picture

- ◆ Select Save Image As from the menu that opens up.
- ◆ Save the image to your folder. (You can give a new name to your picture if needed).

In this way you can collect all the images you need of plants, animals and climatic regions for your digital album and save them to the **Images** folder.

After that you can arrange the digital pictures you have collected and create an album similar to Mini's and save it to your folder.

Shall we use the *LibreOffice Writer* that we are already familiar with to create the album? You may remember that we had learnt to include pictures using *Writer* in earlier classes.

Permission required

When we use information taken from the internet, we should know whether we can use it freely or not. We may need to seek the permission of the person or the organisation that created it.



Let's assess

1. Find images related to Folk arts of Kerala mentioned in the chapter 'Padayani' in the Kerala Padavali using the keyword 'Folk art kerala' on the internet, and save them to your folder.
2. Prepare a write-up on 'The specialities of various fruits ' relating to the chapter 'Flower to Flower' using the key words Simple Fruits, Aggregate Fruits and False Fruits.
3. Collect any four images of plants and animals that live in the desert and save them to a folder.



Extended Activities

1. Collect images relating to the topography of different climatic zones and the plants and animals that live in them. With these images, create a digital album using *LibreOffice Writer*.
2. From the Internet choose pictures of various foods that contain carbohydrates, fats, vitamins and minerals. With the help of *LibreOffice Writer*, prepare a wall poster on 'Nutrients in Food and their Sources'.



Chapter 6

Into the Wonderful World of the Sky



*A moonlit night! Appu went out with his father.
They looked at the sky for a long time.
“How does moon have so much light?”
The moon is not in this shape always, is it?
Does it change its position?
Are there only the sun, the moon and stars in the sky?
Appu has many such doubts*

Don't you also have such doubts?

The sense of wonder instilled in us by the beautiful sights of the sky is really great.

We are unable to see all these astonishing sights with our naked eyes. Usually a telescope is used to observe the sky and its objects.

But telescopes may not be available everywhere.

There are software which imitate the wonders of universe exactly.

Stellarium is such a software.





Let's know the Moon

The waxing and waning of the moon has always fascinated us.

Let's see how the moon can be observed with the help of *Stellarium* software. For this, we have to do some preparations.

With the help of a calendar find out the next New Moon day.

Enter in table 6.1 the time of sunset in the 24 hour clock format.

Activity 6.1

Waxing and Waning of the Moon

We know that the shape of the moon changes as the days pass from the New moon to the Full moon.

Do we have to wait all these days to observe the change?

We can do this activity in the computer using the instructions given below.

- ◆ Open *Stellarium*
Applications → Science → Stellarium
- ◆ Adjust the place to our nearest city.
- ◆ Adjust the date to the New moon date and time to the sunset.
- ◆  Click the **Search window** and type 'Moon' in the search box that opens and find moon.

Next New Moon date:
<input style="width: 100%; height: 20px;" type="text"/>
The time of Sunset :
<input style="width: 100%; height: 20px;" type="text"/>

Table 6.1 New moon and the time of sunset.

- ◆ Click on the tool **Center on selected object** and place the moon at the centre of the screen.
- Zoom and adjust the size of the moon using the **Scroll Wheel** of the mouse.
- ◆ Move the date one day forward in the **Date/Time window**.
- ◆ Observe the changes that happen to the shape of moon.
- ◆ Change the software date a day at a time till you reach the date of the next Full moon day. Observe.
- ◆ Shade the image of the moon(fig 6.1) as you have seen in the *Stellarium* each day and enter the dates.



Date:	Date:	Date:	Date:	Date:	Date:	Date:	Date:
Date:	Date:	Date:	Date:	Date:	Date:	Date:	Date:

Figure 6.1 Let's draw the shapes of the waxing moon



You have now observed the Waxing of the moon.

Change the date in the software a day at a time till it reaches the next New moon day and observe the changes.

Through the Solar system

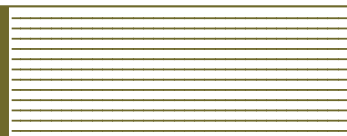
Sky watching will be interesting if we make use of a software to identify the position of the planets.



When we do sky watching with the help of *Stellarium* software we have to adjust the location and time appropriately. We can adjust the location by clicking on the **Location window** tool . Use **Date/time window** tool  to adjust the date and time .

Hide the Earth



Click the **Ground** tool to see the stellar objects beyond the earth.



Figure 6.2 Scorpius constellation

Let's see how we can use *Stellarium* software to locate the planets.

Activity 6.2

Let's view the planets.

Mars is the closest neighbour of the Earth, isn't it? Let's observe Mars in *Stellarium* software.

- ◆ Click on the **Search window** tool in *Stellarium*.
- ◆ In the window that opens type 'Mars' and search for it.
- ◆ Use **Scroll wheel** of the mouse to zoom in and observe Mars.
- ◆ Press **Print Screen** and save the screenshot of the *Stellarium* window.

Similarly, search for the other planets in the solar system. After taking the screenshot give the names of the planets as filenames and save them to your folder. To hide the ground use **Ground** tool. To darken the sky use the **Atmosphere** tool.

Let's make friends with the stars

The white dots in Figure 6.2 indicate stars. If we join the dots, will we get the shape of a scorpion? Try it.

This is the Scorpius constellation that we see right over head at night during the month of August and September and it appears in the shape of a scorpion.

Compare the pictures that you had drawn with the picture of the Scorpius constellation given in the chapter ‘Moon and Stars’ of your Basic Science textbook.



It is an interesting aspect of sky watching to identify constellations on the basis of its shape.

Mind-boggling shapes in the sky can be seen on the computer with the *Stellarium* software.

Activity 6.3

How to identify constellations?

Let’s search the Scorpius constellation making use of the *Stellarium* software.

- ◆ Open the **Search window**, type ‘Scorpius’ in the search box and find the Scorpius constellation.
- ◆ Click the **Constellation lines** tool  and display the line diagram of the Scorpius constellation.
- ◆ Use the **Constellation art** tool  and identify the shape associated with it.
- ◆ Similarly find out the shapes of the constellations given below
 - Orion
 - Leo
 - Virgo

Zodiac

Leo
Virgo
Libra
Scorpius
Sagittarius
Capricornus
Aquarius
Pisces
Aries
Taurus
Gemini
Cancer





Let's assess

1. Using *Stellarium* software, search for the star thiruvathira.
2. Use *Stellarium* to display the picture of constellation that includes thiruvathira.
3. Search for Venus in *Stellarium*. Move a month forward to display the waxing and waning of Venus.



Extended Activities

1. You have prepared a chart of the images of the waxing moon with the help of *Stellarium* (Figure 6.1). Compare these with the actual images of the moon observed during skywatching on the same dates.
2. Select a clear sky at night in February for sky watching.
 - Find out the exact time and position to observe the Orion constellation with the help of *Stellarium*.
 - Observe the sky on that day and identify Orion.



